

Welcome

This Quick Start Guide provides all the information you need to get your product up and running. Please fully unfold this guide and follow the numbered steps below. If you need more detailed instructions, a full user guide is available to download in PDF format from www.bt.com/help/userguides

We haven't printed a full user guide as we're working to make our products greener, so please consider the environment before printing.

If you cannot find the answer to your problem in the full online user guide, then please call the Helpline on 0871 594 1200* or email bt.helpdesk@suncorptech.com

BT is a sustainability leader

To find out how we're making our products greener visit

bt.com/betterworld/products

* Calls cost 6 pence plus 10 pence per minute from a BT residential landline. See www.bt.com/pricing for details. Mobile and other providers' costs may vary.

1 Getting started

Place your BT Synergy 4100 within 2 metres of the mains power socket and telephone socket so that the cables will reach.

The handset range is up to 300 metres outdoors and 50 metres indoors (in ideal conditions). Try to position the phone at least 1 metre away from other electrical appliances to avoid interference and help maximise the handset range. The **Y** icon indicates when you are in range; the handset will beep if you go out of range.

Setting up

1. Plug the mains power adaptor with the **clear plug** (item code 032763) and telephone cable into the underside of the base. **Only use the cables provided.**
2. Plug the power adaptor into the mains power socket and switch the power on. The green **Power/In use** indicator will light up.

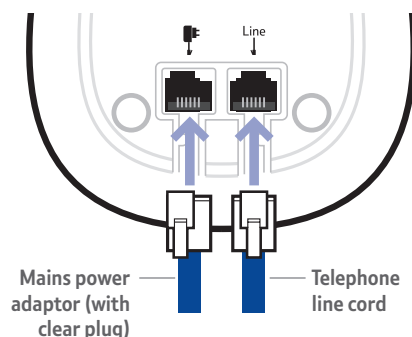

3. Rechargeable batteries are pre-installed in the handset. You need to activate them by pulling the plastic tab away from the bottom of the handset.

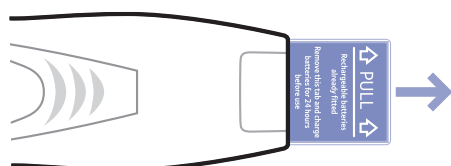

4. Place the handset on the base to charge. The red charging light comes on. **You must charge the handset batteries for at least 24 hours before first use.**
5. When the handset batteries are fully charged, the display will show a full battery icon. Now you can plug the telephone line cord into the telephone wall socket.

Set up your additional handsets (2, 3 and 4-Pack owners only)

For each additional handset and charger:

1. Plug the mains power adaptor with the **red connector** (item code 032765) into the back of the charger and plug the other end into the mains wall socket and switch the power on.
2. Activate the batteries in the handset as detailed in point 3 above. Then place the handset on the charger to **charge for at least 24 hours before first use.**

Additional handsets supplied as part of a multipack are pre-registered to the base so once charged, are ready for use. Each handset will display its own handset number: 1, 2, 3 and so on.

Your BT Synergy 4100 is now ready for use.

2 Navigating the menus

Your BT Synergy 4100 has an easy to use menu system. Each menu has a list of options, which you can see on the menu map below.

1. From the standby screen, press **Menu** or **Menu** to open the main menu and to scroll through the menu options displayed.
2. Press **OK** to select a menu option or **Back** to go back to the previous screen.
Press and hold **End Call** to exit a menu at any time and return to standby.

Menu map

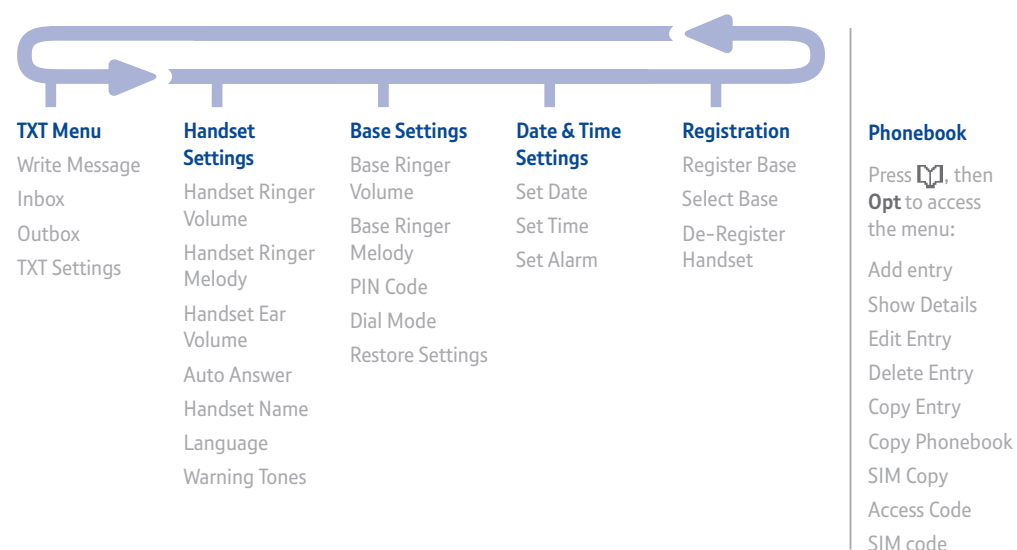

3 Making and receiving calls

Make/end a call

1. Press **Call**, listen for the dialling tone, then dial the number. To end the call, press **End Call**, or replace the handset on the base or charger.

Preparatory dialling

1. Enter the number first. If you make a mistake, press **Del** to delete the last digit.
2. Press **Call** to dial.

Handsfree

1. Press **Call** to switch the call between the earpiece and the loudspeaker.

Secrecy

You can mute the handset microphone and talk without your caller hearing you.

1. **During a call**, press **Sec. Secrecy On** is displayed and you can talk without your caller hearing you. Press **Off** to switch secrecy off and resume your call.

Receiving calls

1. To answer a call press **Call**. Or simply lift the handset if it is on the base or charger.

Redial

The last 20 numbers dialled are stored in the redial list. You can then select any of the numbers to redial, delete or copy to the phonebook.

1. Press **LNR** to open the redial list, the most recently dialled number is displayed. Press **Menu** or **Menu** to scroll through the list.
2. Press **Call** to redial the number. Or press **Copy** to copy the number to the phonebook or **Del** to delete the number from the list.

4 Special features

Your BT Synergy 4100 has some special features, these include a 255 name and number phonebook, Caller Display with calls list, a SIM card reader/writer and SMS text messaging.

Phonebook

You can store up to 255 names and numbers in the phonebook to make dialling quick and easy.

Store a new phonebook entry

1. Press **Opt**. When storing the first entry **Add Entry** is highlighted, press **OK**.
When storing further entries the first entry will be displayed: press **Opt**, **Add Entry** is highlighted, press **OK**.
2. **Enter Name** is displayed. Using the letters on the keypad enter the name, then press **OK**. You may need to press the same button a few times until the letter you want is displayed. For example, press **2** once for **A**, or twice for **B**.
3. **Enter Number** is displayed. Enter the telephone number using the keypad, then press **OK**.
4. The ringer melody options are displayed. Scroll **Menu** or **Menu** to select a melody for your new phonebook entry and press **Save** to confirm. **Entry Saved** is displayed.
5. Press **End Call** to exit and return to standby.

Dial a phonebook entry

1. Press **Opt**. The first entry is displayed.
2. Press **Menu** or **Menu** to scroll through the phonebook, or press the relevant keypad button to search alphabetically. Press **Call** to dial the selected number.

Caller Display and the calls list

You must subscribe to a Caller Display service for this feature to work. Your network provider may charge you for this service.

Caller Display allows you to see the number of the person calling you before you answer the phone. The calls list holds details of your last 50 callers, including the phone number, date and time of the call. If a number matches a stored directory entry, the caller's name is displayed instead.

The calls list also alerts you to missed calls. When you have new missed calls, the  icon will flash in the display and show how many missed calls you have received.

View and dial from the calls list

1. Press . The most recently received call is displayed. **New** is displayed when a call is new (has not yet been viewed). Use  or  to scroll through the list.

When all new calls have been viewed **New** will disappear and the call counter will show the total amount of old calls received.

2. Press  to dial the number. Or press **Copy** to copy the number to the phonebook or **Del** to delete the number from the list.

3. Press  to exit and return to standby.



SIM card reader/writer

Your BT Synergy 4100 has a SIM card reader/writer which allows you to copy entries from a SIM card to the Synergy phonebook and from the Synergy phonebook to a SIM card.

Copy phonebook entries to or from a SIM card

1. Slide out the SIM reader drawer from the side of the base and insert the SIM card.

2. At the handset, press , then **Opt**. Then scroll  to **SIM COPY** and press **OK**.

3. Press  or  to select either **Copy from SIM** or **Copy to SIM** and select **OK**. The display will show **Please Wait** while it checks your SIM card. If your SIM card is PIN protected, enter the SIM card PIN and press **OK**.

COPYING will be displayed. Once complete, the number of entries copied will be displayed.

Text messaging

Before you can send and receive text messages you need to subscribe to the text messaging service (no subscription charge) and to Caller Display (a quarterly fee may be payable, check with your network provider). Please see the online full user guide for details.

To subscribe to the text messaging service

You will be automatically registered when you send your first text message or you can send the word 'Register' to **00000**. You will receive a welcome message back as confirmation.

To access the text messaging menu:

1. Press  or  until **TXT Menu** is displayed and press **OK**. You can now scroll through the menu options: Write Message, Inbox, Outbox and Text Settings.

2. When the option you want is displayed, press **OK** and follow the menu options available.

Multi-handset functions

If you have bought a multiple pack and therefore have more than one handset registered to the base, you can: make internal calls, transfer an external call from one handset to another, hold a conference call and make an internal call between two handsets while a third is on an external call.

For a full explanation of features and instructions, please see the main user guide online at www.bt.com/help/userguides

Troubleshooting

Most problems are caused by something very simple and can be fixed with a few simple checks:

- Make sure both the mains power adaptor cable and telephone line cord are plugged into the correct sockets and plugged in at the wall.
- Make sure you use all the cables and batteries (if supplied) that came in the box, not those from a previous product.
- If you experience poor speech quality or interference, make sure the product is not located too close to other electrical appliances. This can also help improve the handset range from the base.
- Make sure you charge the batteries for at least 24 hours before first use to ensure maximum battery performance. The charge capacity of the batteries will decrease over time.

Using your BT Synergy 4100 on a broadband Internet enabled line?

Remember to plug the phone into the wall socket via an ADSL microfilter if you have broadband Internet on your phone line, otherwise you may have problems with this product and your broadband service. Additional BT ADSL microfilters can be purchased from www.shop.bt.com

General information

For information on safety instructions, cleaning, technical information or connecting to a switchboard, please refer to the 'General Information' section in the full user guide at www.bt.com/help/userguides

Guarantee

Your BT Synergy 4100 is guaranteed for a period of 12 months from the date of purchase.

Subject to the terms listed below, the guarantee will provide for the repair of, or at BT's or its agent's discretion the option to replace the BT Synergy 4100, or any component thereof, (other than batteries), which is identified as faulty or below standard, or as a result of inferior workmanship or materials. Products over 28 days old from the date of purchase may be replaced with a refurbished or repaired product.

The conditions of this guarantee are:

- The guarantee shall only apply to defects that occur within the 12 month guarantee period.
- Proof of purchase is required.
- The equipment is returned to BT or its agent as instructed.

This guarantee does not cover any faults or defects caused by accidents, misuse, fair wear and tear, neglect, tampering with the equipment, or any attempt at adjustment or repair other than through approved agents.

This guarantee does not affect your statutory rights.

For further information within and outside the 12 month guarantee, please refer to the full user guide at www.bt.com/help/userguides

Product disposal instructions



The symbol shown here and on the product means that the product is classed as Electrical or Electronic Equipment and should not be disposed with other household or commercial waste at the end of its working life.

The Waste of Electrical and Electronic Equipment (WEEE) Directive (2002/96/EC) has been put in place to recycle products using best available recovery and recycling techniques to minimise the impact on the environment, treat any hazardous substances and avoid the increasing landfill.

Product disposal instructions for residential users

When you have no further use for it, please remove any batteries and dispose of them and the product as per your local authority's recycling processes. For more information please contact your local authority or the retailer where the product was purchased.

Product disposal instructions for business users

Business users should contact their suppliers and check the terms and conditions of the purchase contract and ensure that this product is not mixed with other commercial waste for disposal.

R&TE Directive & Declaration of Conformity

This product is intended for use within the UK for connection to the public telephone network and compatible switchboards.

This equipment complies with the essential requirements for the Radio Equipment and Telecommunications Terminal Equipment Directive (1999/5/EC).

The Declaration of Conformity is published on the website <http://www.suncorptech.com/bt>

BT is a sustainability leader

To find out how we're making our products greener visit

bt.com/betterworld/products

Offices worldwide

The services described in this publication are subject to availability and may be modified from time to time. Services and equipment are supplied subject to British Telecommunications plc's respective standard conditions of contract. Nothing in this publication forms any part of a contract.

© British Telecommunications plc 2008.
Registered Office: 81 Newgate Street, London EC1A 7AJ.
Registered in England No. 1800000.

Designed and produced by The Art & Design Partnership Ltd.

Printed in China / Issue 2 / ADP01-08



BT Synergy 4100 Quick Start Guide



Bringing it all together



A full user guide can be downloaded in PDF format from www.bt.com/help/userguides
Please consider the environment before printing.



This guide can be recycled.